



# 1.3M CVBS CAMERA

## CS-15XXM1



- WDR color CMOS
- Die-casting housing
- Waterproof (IP69K)
- 9 pcs of IR LEDs for night
- Photo sensor
- Audio Built-in

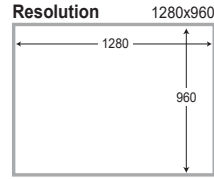

**WDR** Infrared rearview camera has wide visual field and prevent accident in the rear of vehicle by realtime clean image even night.

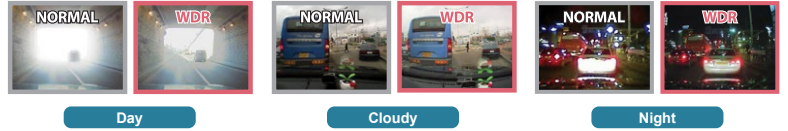

## MODEL NAME & VIEW ANGLE

**CS-1509M1**  
87(H) / 65(V) / 108(D)

**CS-1512M1**  
118(H) / 87(V) / 150(D)

## DIMENSIONS & CABLE

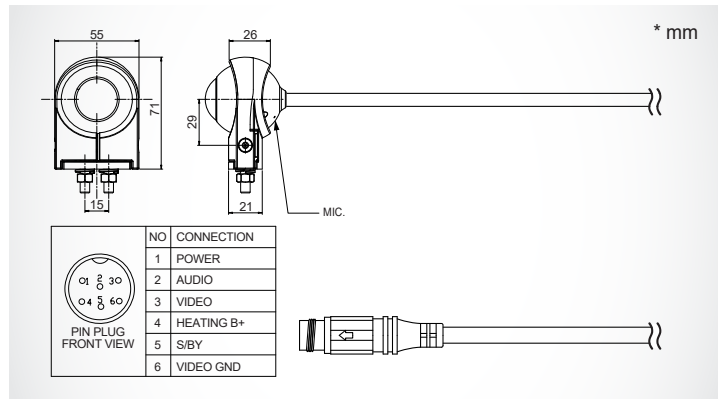

## VIEW OF ANGLE

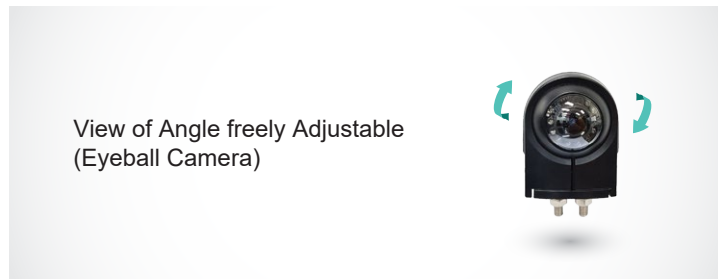

## CABLE CONNECTION

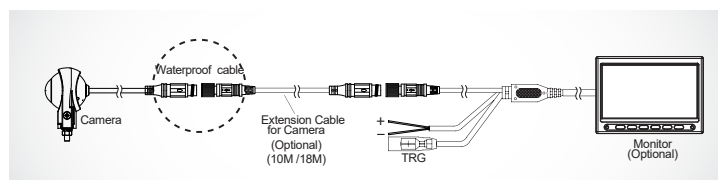

## SPECIFICATION

DEVICE	IMAGE DEVICE	1.3M WDR SENSOR 1/3.2"		
	IMAGE PIXEL SIZE	3.5 $\mu$ m (H) x 3.5 $\mu$ m (V)		
	RECORDING PIXEL	1,280(H) x 960(V) 1.23M Pixel		
	SIGNAL FORMAT	CVBS		
	ASPECT RATIO	4:3		
	FRAME RATE	60fps		
	SCAN MODE	Interlace		
	TV SYSTEM	NTSC TV SYSTEM	PAL TV SYSTEM	
	IMAGE FREQUENCY	HORIZONTALITY	15.734KHz	15.625KHz
		VERTICAL	59.94Hz	50Hz
	VIDEO OUT	Composite video-out / 1.1Vp-p $\pm$ 10%, 75 $\Omega$		
	S/N RATIO	More Than 50dB (AGC OFF)		
	WHITE BALANCE	Auto		
	OUTPUT	VIDEO PORTS	Exclusive 6 pin connector	
		VIDEO TYPE	MIRROR OR NORMAL	
	MIC	O		
	IR LED / PHOTO SENSOR	IR 9ea / Photo sensor 1ea		
	VIEW ANGLE	CS-1509M1	87(H) / 65(V) / 108(D)	
CS-1512M1		118(H) / 87(V) / 150(D)		
MIN. ILLUMINATION	IR ON 0 Lux			
INPUT VOLTAGE	DC 12-24V (MAX 30V)			
OPERATING TEMPERATURE	-20 $^{\circ}$ C ~ 70 $^{\circ}$ C			
STORAGE TEMPERATURE	-30 $^{\circ}$ C ~ 80 $^{\circ}$ C			
WATERPROOF	IP69K			
DIMENSION	55(Dia) x 71(D) mm (with Bracket)			
WEIGHT	160g (with Bracket)			
CABLE LENGTH	1.0m			
BOX CONTENTS	BRACKET · SUNVISOR	O		
	SCREWS SET	O		
	EXTENSION CABLE	Option		
	MANUAL	O		